

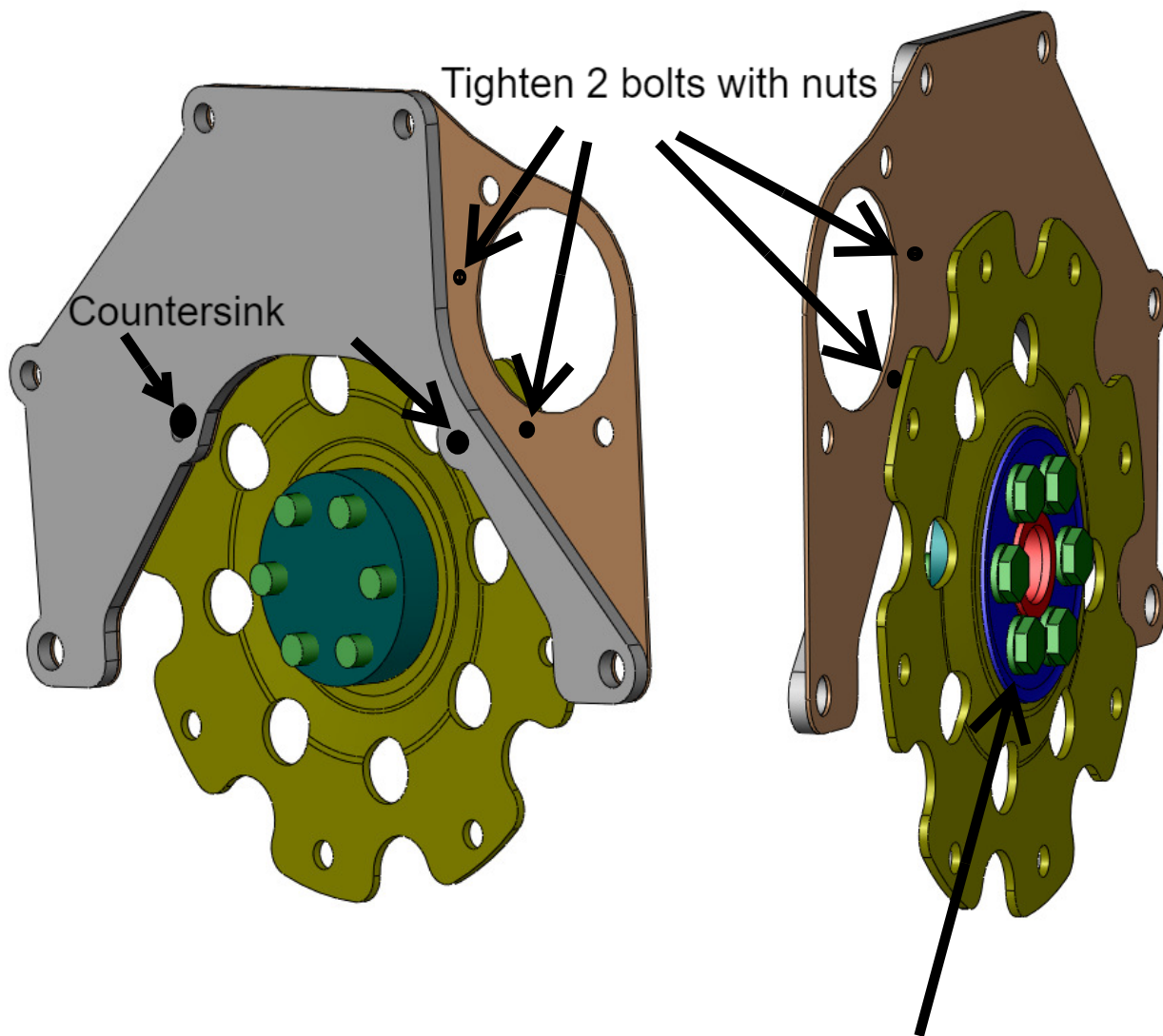

Kiggly Racing 6-Bolt Engine to 2g Adapter Kit Instructions

This kit allows the installation of a 6-bolt engine to a 2g automatic transmission. It fixes the pump spacing issues that would otherwise destroy the pump.

The following pictures show how all the parts are assembled.



*NOTE: The flexplate spacer is optional.

Kiggly Racing

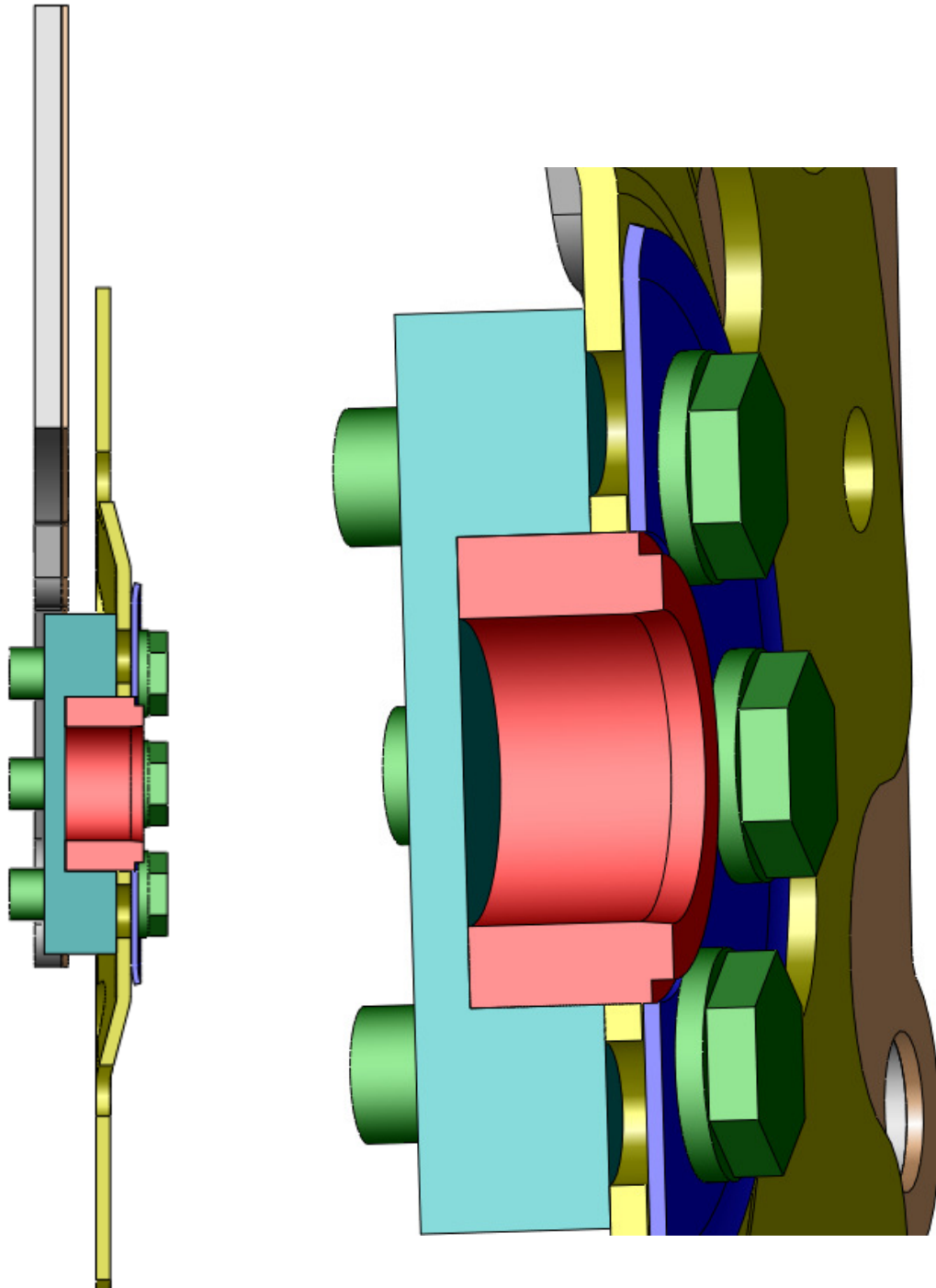

Kiggly Racing

Flexplate

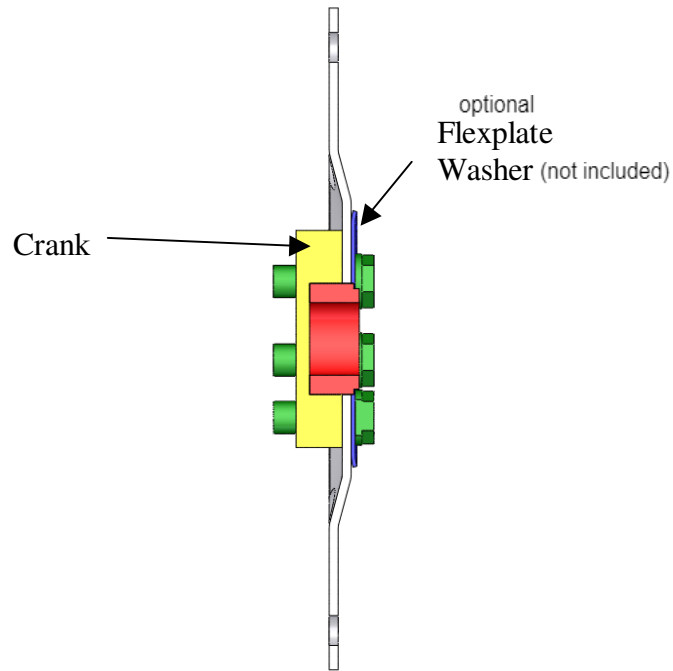

Converter bolts should be tightened to 50ft-lbs or greater with red Loctite. Re-torque the bolts after the first heat cycle. We recommend OEM Crankshaft bolts.*

*additional technical info is available on the website: <https://www.kigglyracing.com/tech-data>